

This drawing is the sole property of Miether Bearing Products and contains confidential and proprietary information. It is being provided to you for your use and may not be disclosed to any third party or used for any other purpose without Miether's prior written consent. The [materials] must be returned to the Company upon its demand. Your acceptance of these materials constitutes your acceptance of the foregoing terms.

C-35205

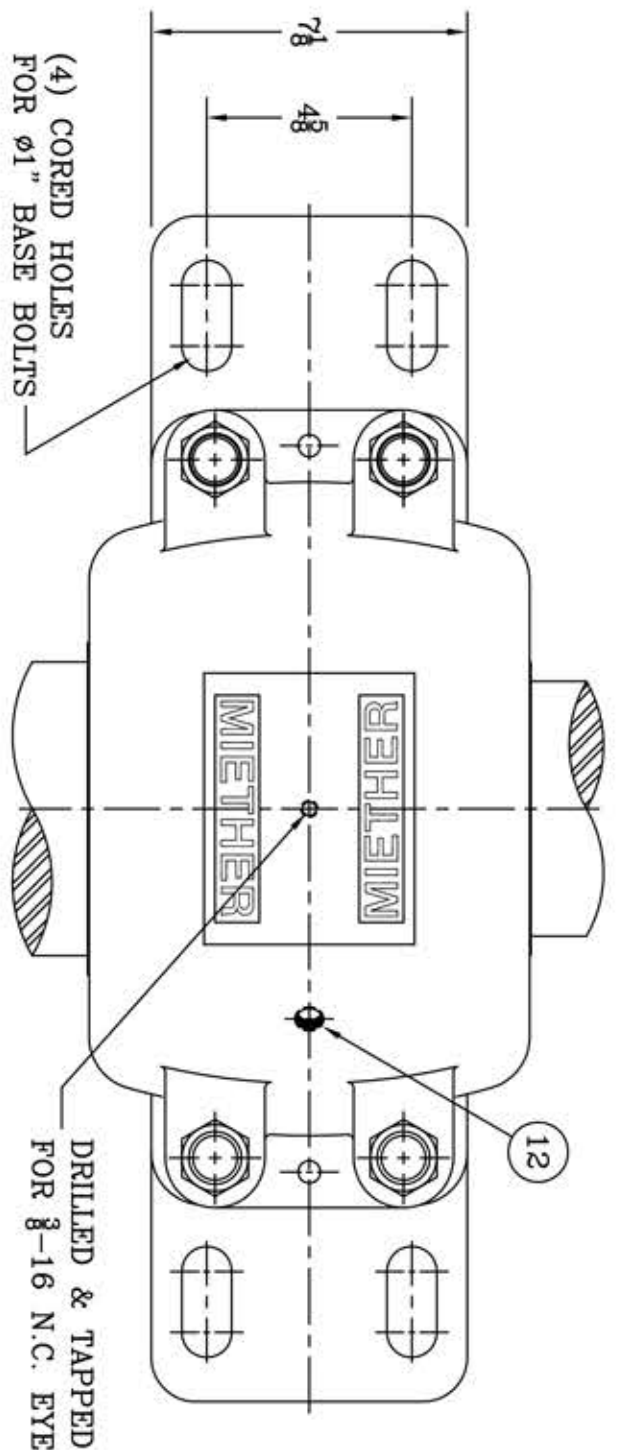

ITEM	DESCRIPTION	DETAIL	REQUIRED
1	HOUSING SAFD 330	C-	1 1
2	SPHERICAL ROLLER BEARING	22330/W-33	1 1
3	STABILIZING RING SR-36-30	A-10610	1 0
4	LOCKNUT AN-30	B-10419	1 1
5	LOCKWASHER W-30	00249	1 1
6	TRIPLE SEAL RING LER-134	A-10621	1 1
7	TRIPLE SEAL RING LER-151	A-10620	1 1
8	DOWEL $\phi \frac{1}{2}$ x 1" LONG		2 2
9	CAP BOLT SQUARE HEAD GR.5	1-8 NC x $1\frac{1}{2}$ LONG	4 4
10	CAP BOLT HEX. NUT	1-8 NC	4 4
11	LOCKWASHER	1" SPLIT MED.	4 4
12	PIPE PLUG	$\frac{3}{8}$ -18 NPT	3 3

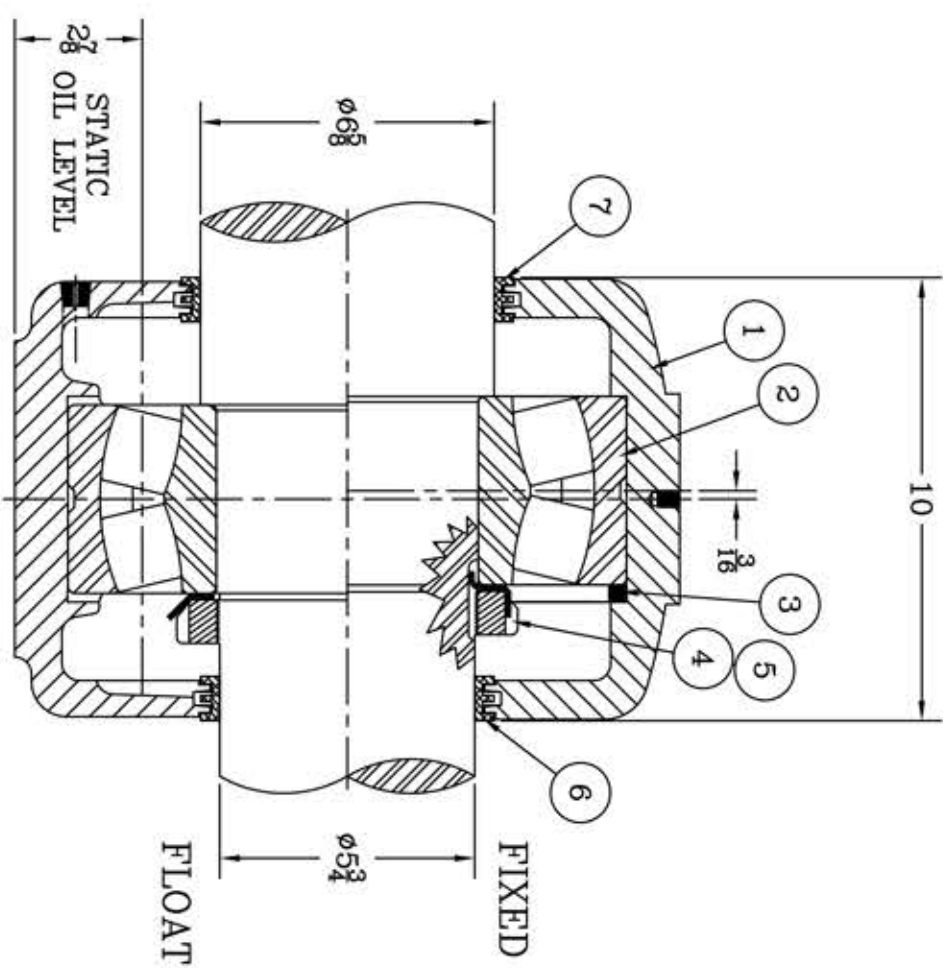
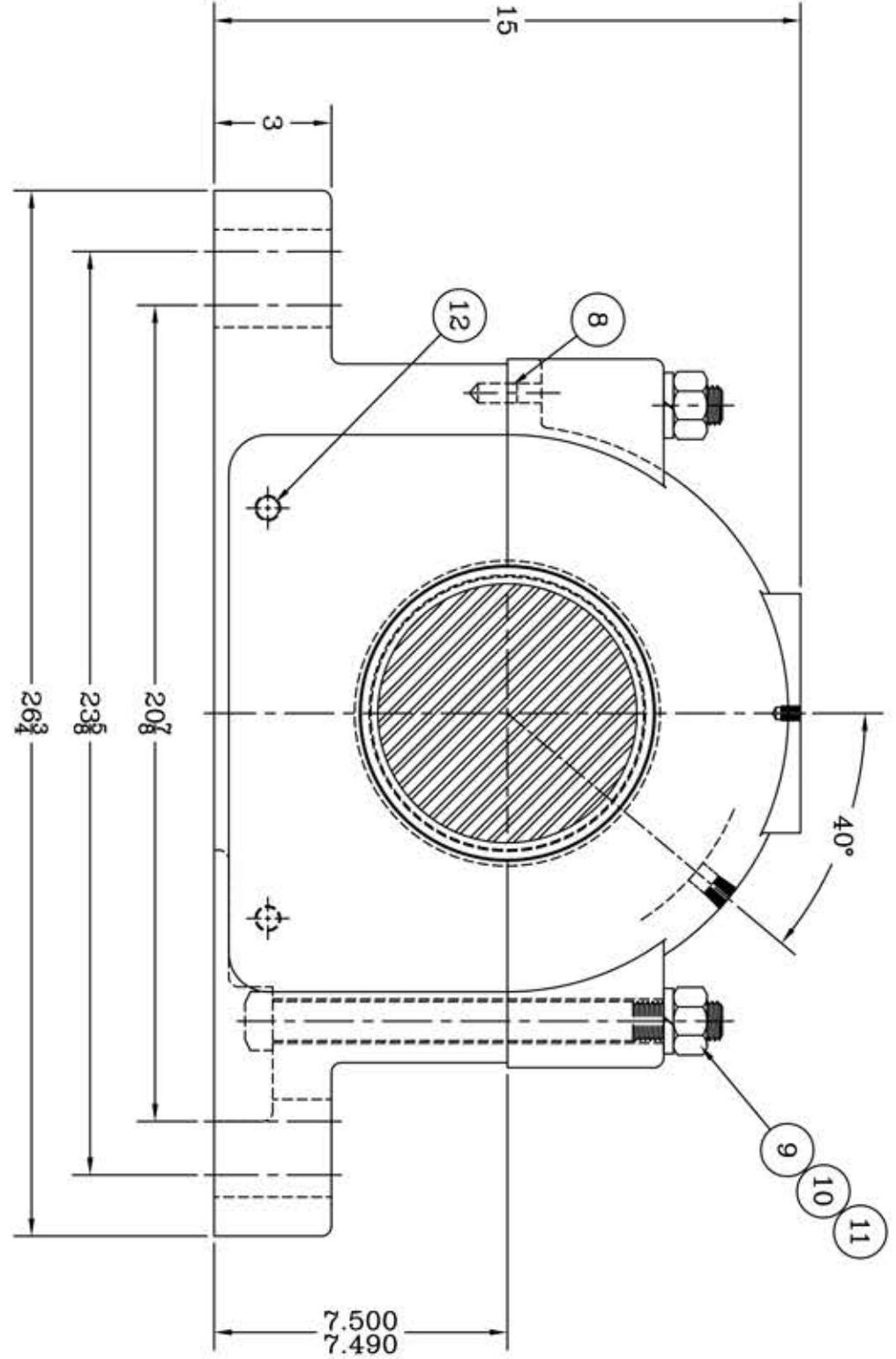

REVISIONS

SYMBOL	DESCRIPTION
C	16
D	32
E	63
F	125
G	250
J	500
K	1000

TOLERANCE: UNLESS OTHERWISE SPECIFIED

FRACTIONS $\pm 1/32$ "

DECIMALS $\pm .005$ "

CASTING $\pm 1/16$ "

WELD $\pm 1/16$ "

ANGLES $\pm 30^\circ$

A.I.S.I. STANDARD FINISHES

AN ALCO INDUSTRIES COMPANY
BEARING PRODUCTS
ODESSA, TX USA

SAFD 22330 06-10 x 05-12

ASSEMBLY DRAWING

SCALE 1 = 3

DRAWN PCF

DATE 12/31/12

CHK:

ASSEMBLY NO.

DRAWING NO. C-35205